

BRIDAS EMI GROUP S.A.

30kg/Cm²

JIS B 2220-1984(KS B 1503-1999)

30kg/cm² SLIP-ON WELDING STEEL PIPE FLANGES

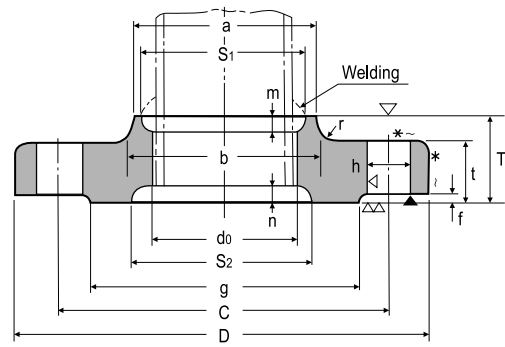

* The surface finish (▽) is in the case of die forging

TYPE B
NOMINAL SIZE 10~50mm

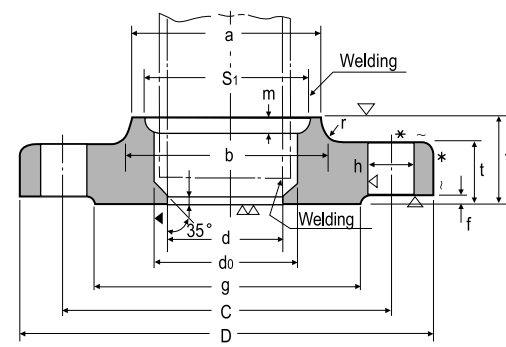

TYPE C
NOMINAL SIZE 65~400mm

40kg/Cm²

JIS B 2216-1984(KS B 1503-1999)

40kg/cm² SLIP-ON WELDING STEEL PIPE FLANGES

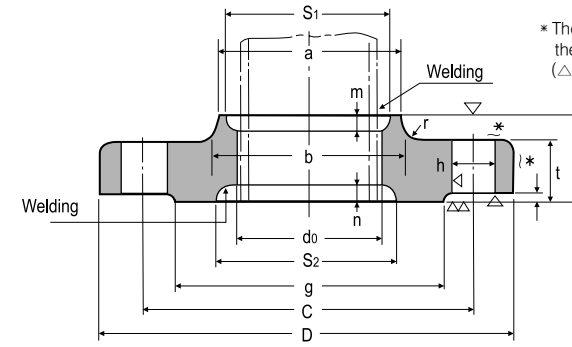

* The surface finish is in the case of forging (▽) in other cases

NOMINAL SIZE 10~65mm

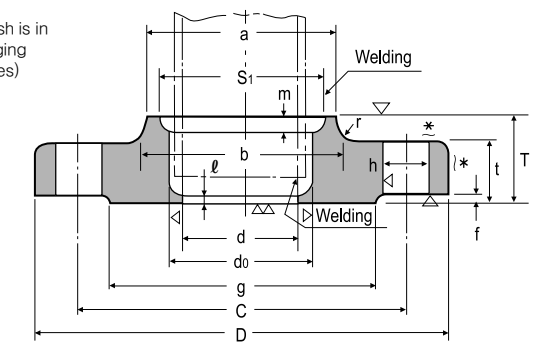

NOMINAL SIZE 65~400mm

Unit:mm

Nominal Diam. of Flange	Outside Diam. of Steel Pipe	Outside Diam. of Flange d _b	Outside Diam. of Flange D	Sectional Dimensions of Flange								Bolt Hole				Reference					Approx. Weigh (kg)
				t	T	Diam. of Hub		Radius r	Raised face g	Diam. of Radius face g	d	Bolt Circle Diam C	Number of Bolt Holes	Hole Diam h	Nominal Bolt Size	S ₁	m	S ₂	n	l	
						a	b														
10	17.3	17.8	110	16	24	30	34	4	1	52	-	75	4	19	M16	-	-	-	-	-	0.99
15	21.7	22.2	115	18	26	36	40	5	1	55	-	80	4	19	M16	31	4	40	5	-	1.23
20	27.2	27.7	120	18	26	42	46	5	1	60	-	85	4	19	M16	37	5	44	5	-	1.34
25	34.0	34.5	130	20	30	50	54	5	1	70	-	95	4	19	M16	44	6	52	5	-	1.76
32	42.7	43.2	140	22	32	60	64	6	2	80	-	105	4	19	M16	52	6	60	5	-	2.15
40	48.6	49.1	160	22	34	66	70	6	2	90	-	120	4	23	M20	58	6	66	5	-	2.82
50	60.5	61.1	165	22	36	82	86	6	2	105	-	130	8	19	M16	70	6.5	78	5	-	2.89
65	76.3	77.1	200	26	40	102	106	8	2	130	65.9	160	8	23	M20	96	9.5	94	5	6	4.70
80	89.1	90.0	210	28	44	115	121	8	2	140	78.1	170	8	23	M20	109	9.5	-	-	6	5.36
(90)	101.6	102.6	230	30	46	128	134	8	2	150	90.2	185	8	25	M22	122	9.5	-	-	6	6.85
100	114.3	115.4	240	32	48	141	147	8	2	160	102.3	195	8	25	M22	135	9.5	-	-	6	7.89
125	139.8	141.2	275	36	54	166	172	8	2	195	126.6	230	8	25	M22	160	9.5	-	-	6	11.4
150	165.2	166.6	325	38	58	196	204	8	2	235	151.0	275	12	27	M24	186	9.5	-	-	6	16.7
200	216.3	218.0	370	42	64	248	256	8	2	280	199.9	320	12	27	M24	237	9.5	-	-	6	20.6
250	267.4	269.5	450	48	72	306	314	10	2	345	248.8	390	12	33	M30×3	290	10	-	-	6	36.1
300	318.5	321.0	515	52	78	360	370	10	3	405	297.9	450	16	33	M30×3	345	12	-	-	6	49.9
350	355.6	358.1	560	54	84	402	412	12	3	450	333.4	495	16	33	M30×3	383	13	-	-	6	61.2
400	406.4	409.0	630	60	92	456	468	15	3	510	381.0	560	16	39	M36×3	435	14	-	-	7	85.2

- Notes: (1) As far as possible nominal diameter in parenthesis should be avoid from use.
 (2) The dimensional tolerance shall confirm to JIS B2203
 (3) The flange gasket surface is based on large raised facing specified in JIS B2202 But if necessary facings other than the large raised facing specified in JIS B2201 can be designated by customers.
 (4) Sized is an example of pipe thickness for schedule 40 of JIS G3454 and JIS B3456, When other size is necessary customers can order it at will.
 (5) Material
 Carbon Steel : S25C specified in JIS G4051 or SF45 specified in JIS G3201.
 Molybdenum Steel : 1/2Mo Steel specified in tables 1 and 2 of JIS B2215.
 Chromium-Molybdenum Steel : 1/4 Cr1/2 Mo Steel specified in tables 1 and of JIS B2215
 * The surface finish is the case of forging (▽) in other cases)

Unit:mm

Nominal Diam. of Flange	Outside Diam. of Steel Pipe	Inside Diam. of Flange d _b	Outside Diam. of Flange D	Sectional Dimensions of Flange								Bolt Hole				Reference					Approx. Weigh (kg)
				t	T	Diam. of Hub		Radius r	f	g	d	Bolt Circle Dia C	Number of Bolt Holes	Hole Dia h	Nominal Bolt Size	S ₁	m	S ₂	n	l	
						a	b														
10	17.3	17.8	110	18	26	34	38	5	1	52	-	75	4	19	M16	28.0	6	28	5	-	1.11
15	21.7	22.2	115	20	30	39	43	5	1	55	-	80	4	19	M16	32.5	6	32.5	5	-	1.39
20	27.2	27.7	120	20	30	45	49	5	1	60	-	85	4	19	M16	38.0	6	38.0	5	-	1.51
25	34.0	34.5	130	22	32	55	59	5	1	70	-	95	4	19	M16	47.8	6	47.8	5	-	1.97
32	42.7	43.2	140	24	35	64	68	3	2	80	-	105	4	19	M16	56.5	6	56.5	5	-	2.50
40	48.6	49.1	160	24	35	70	74	6	2	90	-	120	4	23	M20	62.5	6	62.5	5	-	3.26
50	60.5	61.1	165	26	38	86	90	6	2	105	-	130	8	19	M16	74.5	6	74.5	5.5	-	3.47
65	76.3	77.1	200	30	44	106	110	8	2	130	62.3	160	8	23	M20	91.5	7	91.5	7	-	5.97
80	89.1	90.3	210	32	46	118	124	8	2	140	73.9	170	8	23	M20	105.5	7.5	105.5	7	-	6.76
100	114.3	115.5	250	36	52	145	151	8	2	165	97.1	205	8	25	M22	133.0	8.5	133.0	7	-	10.48
125	139.8	141.4	300	40	58	182	188	8	2	200	120.8	250	8	27	M24	160.5	9.5	160.5	7	-	16.97
150	165.2	167.0	355	44	64	200	208	8	2	240	143.2	295	12	33	M30	188.0	11	188.0	7	-	22.6
200	216.3	218.2	405	50	72	255	263	8	2	290	190.9	345	12	33	M30	243.0	13	243.0	7	-	34.9
250	267.4	269.5	475	56	80	310	318	10	2	355	237.2	410	12	33	M30	298.0	15	298.0	7	-	41.4

- Notes: (1) As far as possible nominal diameter in parenthesis should be avoid from use.
 (2) The dimensional tolerance shall confirm to JIS B2203
 (3) The flange gasket surface is based on large raised facing specified in JIS B22020 But if necessary facings other than the large raised facing specified in JIS B2201 can be designated by customers.
 (4) Sized is an example of pipe thickness for schedule 40 of JIS G3454 and JIS B3456, When other size is necessary customers can order it at will.
 (5) Refer to JIS B2216

10kg/Cm²

JIS B2220-1984 (KS B 1503-1999)

10kg/cm² WELDING NECK STEEL PIPE FLANGES

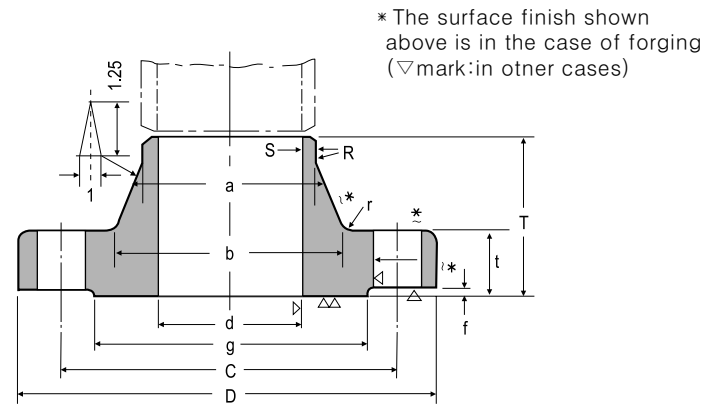

Reference: Beveling

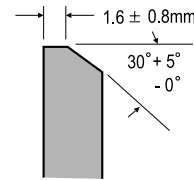

When particularly necessary, customers can order another beveling form the above.

Unit:mm

Nominal Diam. of Flange	Outside Diam. of Steel Pipe	Outside Diam. of Flange do	Outside Diam. of Flange D	Sectional Dimensions of Flange									Nominal Bolt Size	Length of wecr Depat P *	Approx. Weighth (kg)	
				t	T *1	Diam. of Hub		Rad-iusr *3	Raised Face f	Diam. Raised Face g	Bolt Caised Bolt Holes	Number of Bolt Holes				Hole Dia. h
						a	b									
10	17.3		90	12	28.9	17.3	25	4	1	46	65	4	15	M12	3.5	
15	21.7		95	12	30.6	21.7	33	4	1	51	70	4	15	M12	4.5	
20	27.2		100	14	33.9	27.2	38	4	1	56	75	4	15	M12	6.4	
25	34		125	14	36.3	34.0	47	4	1	67	92	4	19	M16	6.0	
32	42.7		135	16	40.3	42.7	57	5	2	76	100	4	19	M16	6.4	
40	48.6		140	16	41.2	48.6	64	5	2	81	105	4	19	M16	5.9	
50	60.5		155	16	42.9	60.5	77	5	2	96	120	4	19	M16	6.3	
65	76.3		175	18	53.0	76.3	97	5	2	116	140	4	19	M16	9.1	
80	89.1		185	18	53.0	89.1	109	6	2	126	150	8	19	M16	9.6	
(90)	101.6		195	18	50.6	101.6	120	6	2	136	160	8	19	M16	9.6	
100	114.3		210	18	54.3	114.3	135	6	2	151	175	8	19	M16	10.4	
125	139.8		250	20	56.2	139.8	160	6	2	182	210	8	23	M20	10.9	
150	165.2		280	22	65.3	165.2	190	6	2	212	240	8	23	M20	12.3	
(175)	190.7		305	22	66.1	190.7	215	6	2	237	265	12	23	M20	13.7	
200	216.3		330	22	66.1	216.3	240	6	2	262	290	12	23	M20	14.4	
(225)	241.8		350	22	62.3	241.8	262	6	2	282	310	12	23	M20	15.0	
250	267.4		400	24	70.7	267.4	292	6	2	324	355	12	25	M22	15.9	
300	318.5		445	24	75.9	318.5	346	6	3	368	400	16	25	M22	17.5	
350	355.6		490	26	83.0	355.6	386	8	3	413	445	16	25	M22	19.0	
400	406.4		560	28	94.4	406.4	442	8	3	475	510	16	27	M24	21.9	
450	457.2		620	30	107.9	457.2	502	10	3	530	565	20	27	M24	21.9	
500	508		675	30	110.2	508.0	554	10	3	585	620	20	27	M24	22.7	
550	558.8		745	32	119.9	558.8	610	10	3	640	680	20	23	M30	23.9	
600	609.6		795	32	123.6	609.6	662	10	3	690	730	24	33	M30	26.1	

Notes: (1) *1 *2 *4 Dimensions of "T" "r" "s" "p" are maker A JOO FITTING standard.
 (2) *2 Under nominal size 225m/m & under Dimension of "b" is maker A JOO FITTING standard
 (3) All Dimensions of Flange was Dimension on JIS B2220 & KS B1503 base

20kg/Cm²

JIS B2220-1984 (KS B 1503-1999)

20kg/cm² WELDING NECK STEEL PIPE FLANGES

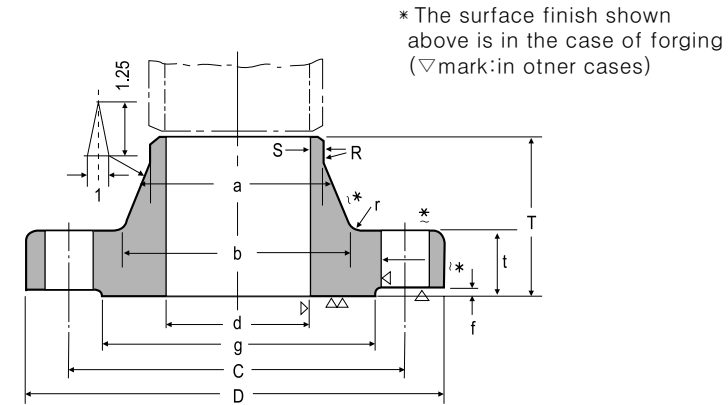

Reference: Beveling

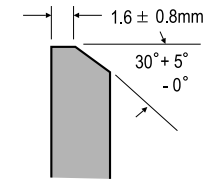

When particularly necessary, customers can order another beveling form the above.

Unit:mm

Nominal Bore of Flange	Outside Diam. of Steel Pipe	Outside Diam. of Flange D	t	d	Sectional Dimensions of Flange									Bolt Hole			Nominal Bolt Size	Approx. Weighth (kg)	
					a	b	S	T	P	Radius	f	g	Bolt Diameter Circle C	Number of Bolt Holes	Diamet-er of Hole h				
10	17.3	90	14		17.3	32				35.9	3.5	4	1	46	65	4	15	M12	
15	21.7	95	14		21.7	36				36.4	4.5	4	1	51	70	4	15	M12	
20	27.2	100	16		27.2	42				40.9	6.4	4	1	56	75	4	15	M12	
25	34.0	125	16		34.0	50				42.0	6.0	4	1	67	90	4	19	M16	
32	42.7	135	18		42.7	60				46.0	6.4	5	2	76	90	4	19	M16	
40	48.6	140	18		48.6	66				45.7	5.9	5	2	81	105	4	19	M16	
50	60.5	155	18		60.5	80				48.7	6.3	5	2	96	120	8	19	M16	
65	76.3	175	20		76.3	104				63.7	9.1	5	2	116	140	8	19	M16	
80	89.1	200	22		89.1	117				66.5	9.6	6	2	132	160	8	23	M20	
90	101.6	210	24		101.6	130				68.9	9.4	6	2	145	170	8	23	M20	
100	114.3	225	24		114.3	142				69.0	10.4	6	2	160	185	8	23	M20	
125	139.8	270	26		139.8	172				77.2	10.9	6	2	195	225	8	25	M20	
150	165.2	305	28		165.2	202				86.3	12.3	6	2	230	260	12	25	M22	
200	216.3	350	30		216.3	252				89.0	14.4	6	2	275	305	12	25	M22	
250	267.4	430	34		267.4	312				105.7	15.9	6	2	345	380	12	27	M22	
300	318.5	480	36		318.5	364				110.4	17.5	8	3	395	430	16	27	M24	
350	355.6	540	40		355.6	408				124.5	19.0	8	3	440	480	16	33	M24	
400	406.4	605	46		406.4	456				129.9	21.9	10	3	495	540	16	33	M30×3	
450	457.2	675	48		457.2	514				140.9	21.9	10	3	560	605	20	33	M30×3	
500	508.0	730	50		508.0	568				147.7	22.7	10	3	615	660	20	33	M30×3	
550	558.8	795	52		558.8	622				154.9	23.9	10	3	670	720	20	39	M36×3	
600	609.6	845	54		609.6	676				163.1	26.1	10	3	720	770	24	39	M36×3	

Notes: Dimesions are marker standard and design base is JIS B2220-1984



BRIDAS EMI GROUP S.A.

info@bridasemi.com.ar

www.bridasemi.com.ar

Rondeau 1560 Wilde, Buenos Aires. Argentina

Tel: 4220 -4414 4414 /4289 4572 - 4289 2030 / 4137 7325